

LIQUID LEAKAGE SENSOR

OPERATION MANUAL

for

Detection Unit: RS-3500 series

Control Unit: RS-3500C*

(*Available use with Detection Unit RS-3500-BZ series)

TOYOKO KAGAKU CO., LTD.
Components Business Division
370 Ichinotsubo, Nakahara-Ku, Kawasaki-City, Kanagawa-Pref., JAPAN
Phone: (044)435-5860 Fax: (044)433-5332

(Patent. 1783360)
MAN-RS35B-04.10

Introduction

We appreciate that you have purchased our Liquid Leakage Sensor. Before you install or operate it, please read this operation manual thoroughly, and follow the instruction in order to avoid any accidents, malfunction, defects and hazards. Please keep this manual with good care as long as the sensor is being operated.

Table of Contents

- 1. Designation of Sensors**
 - 1-1. Detection Unit.....3
 - 1-2. Control Unit RS-3500C.....3
- 2. Installation**
 - 2-1. RS-3500FA.....4
 - 2-2. RS-3500FAP.....4
 - 2-3. RS-3500C.....6
- 3. Wiring Instruction**
 - 3-1. Detection Unit without Control Unit7
 - 3-2. Control Unit with Detection Units.....8
- 4. Operation**
 - 4-1. Detection Unit.....9
 - 4-2. Control Unit.....9
 - 4-3. Distinction of the abnormal status10
- 5. Reset Procedure after Alarm Clearance 11**
- 6. Specification12**
 - 6-1. Detection Unit.....12
 - 6-2. Control Unit.....12

1.Designation of Sensors

1-1. Detection Unit

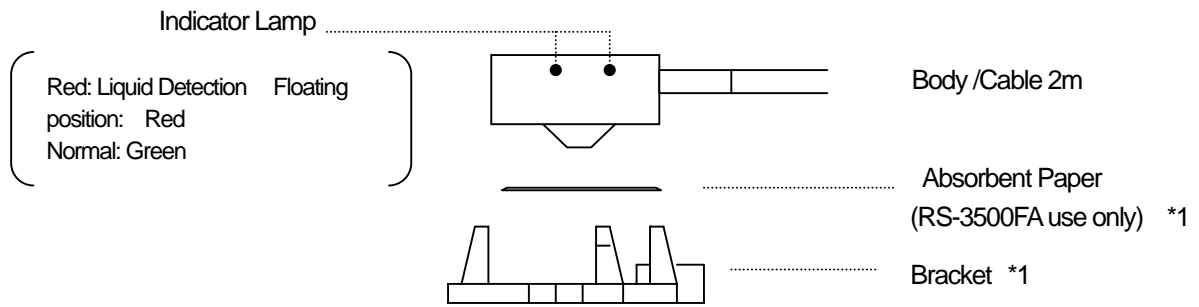

*1: The Bracket is different for RS-3500FA and for RS-3500FAP. These differences are adsorbent paper use or not. For details, refer page 6. Specifications.

1-2. Control Unit: RS-3500C

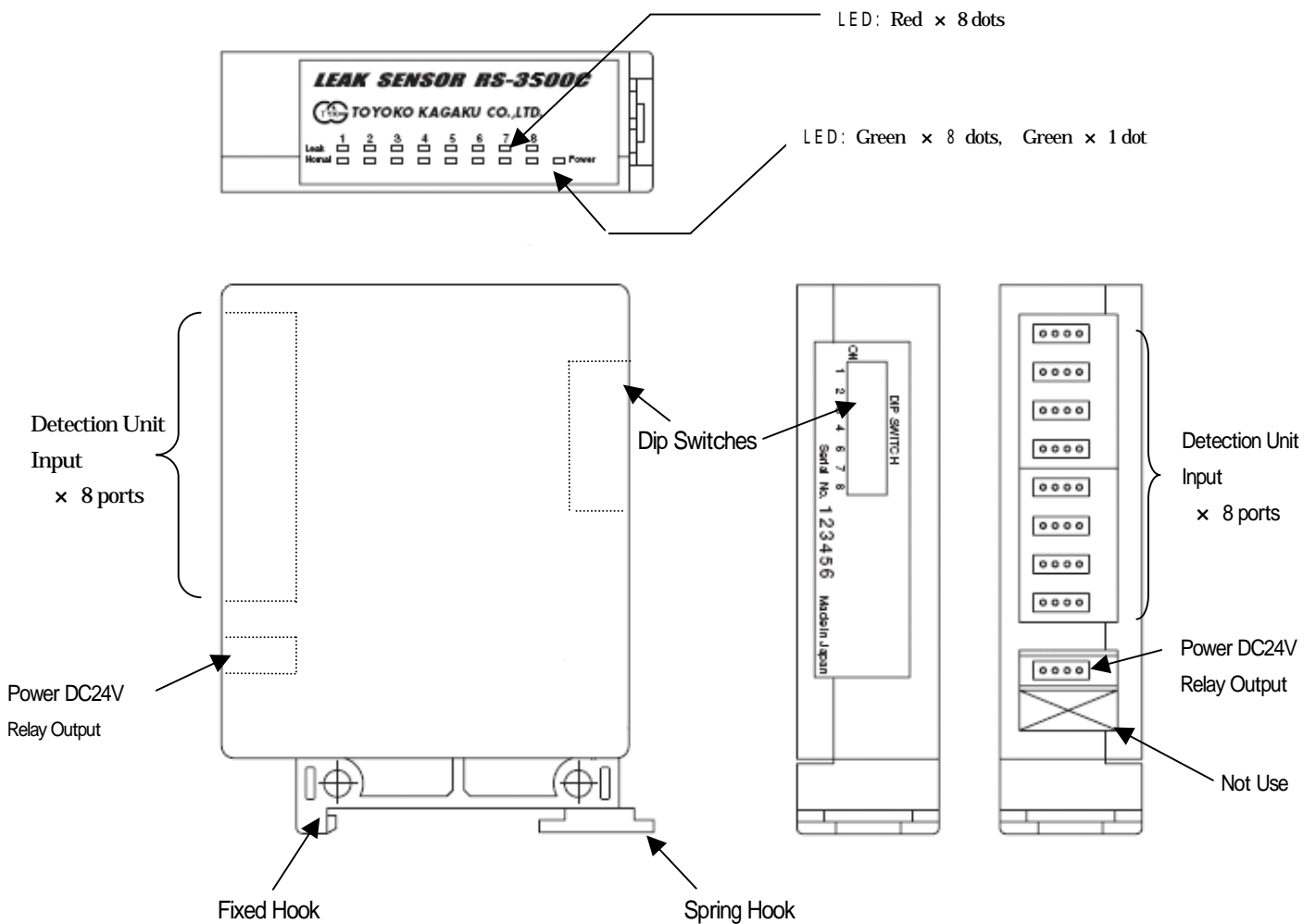

Attachment for DIN Rail and 2 holes for screw-down

2. Installation

2-1. Detection Unit: RS-3500FA

(1) Place the Bracket of the Detection Unit on the surface where you want to detect the leakage, and fix it firmly.

Use the correct Bracket for the detection Unit. Refer to page 9 Specification.

(2) Place a piece of the Absorbent paper onto the Bracket.

**NOTE: Be aware not to use 2 or more pieces of the Paper at a time in the Bracket.
To mount the Sensor Body, push it into the Bracket completely.**

NOTE: Verify that the Body has fixed entirely and it does not hook up at intermediate height in the Bracket.

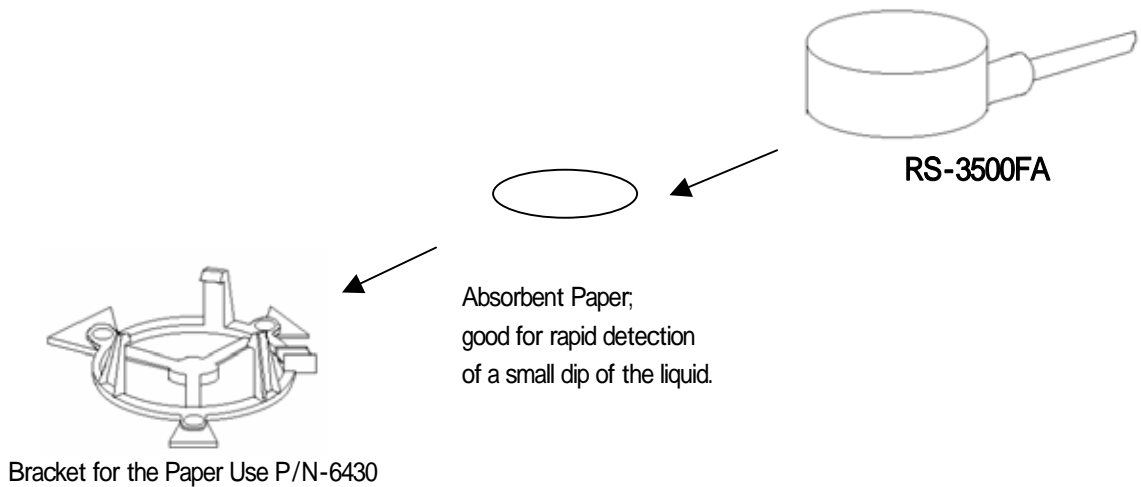

2-2. Detection Unit: RS-3500FAP

(1) Place the Bracket of the Detection Unit on the surface where you want to detect the leakage, and fix it firmly.

Use the correct Bracket for the detection Unit. Refer to page 9 Specification

(2) To mount the Sensor Body, push it into the Bracket completely.

NOTE: Verify that the Body has fixed entirely and it does not hook up at intermediate height in the Bracket.

NOTE: Do not use any adsorbent paper for this model.

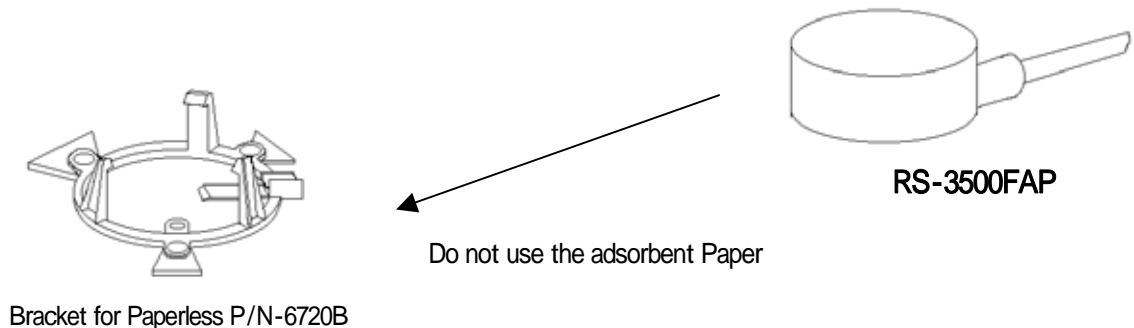

NOTE: When the sensor is located at the position, align the direction of the detection unit against the Bracket as described below.

And make sure that the location of the sensor will not have any difficulties for maintenance job, or the direction of the cable heads for no obstructions where the cable may not be damaged by excessive bent or pressure.

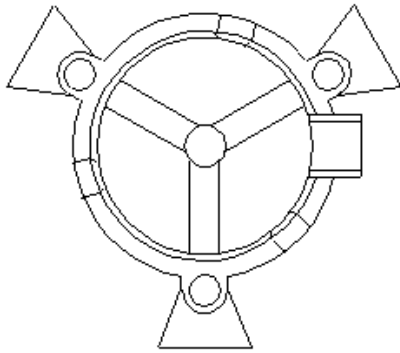

Top View

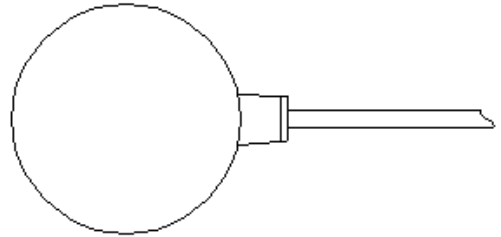

Side View

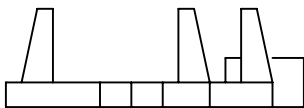

Bracket

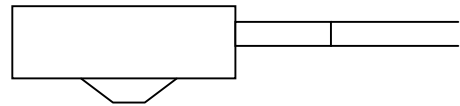

Detection Unit

2-3. Control Unit RS-3500C

The RS-3500C Control Unit can install onto either DIN Rail or the surface of the plate.

(1) Install the unit onto the DIN Rail as below.

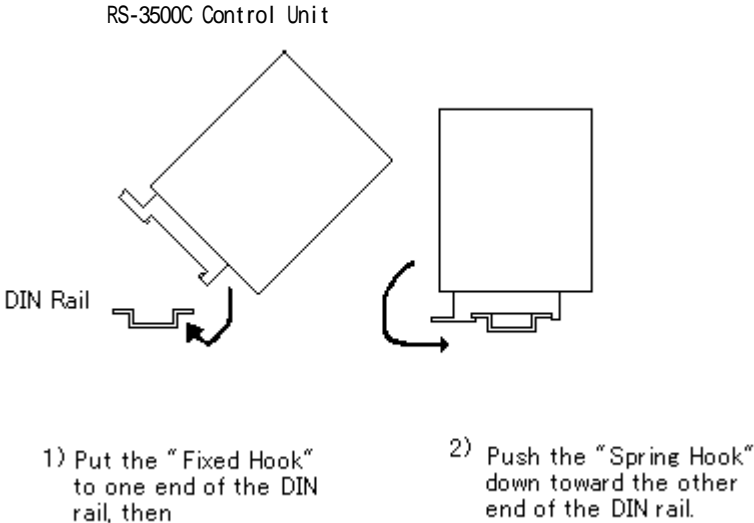

(2) When DIN Rail may not be applied, install the unit on the surface directly to be fixed using two of the screw as below.

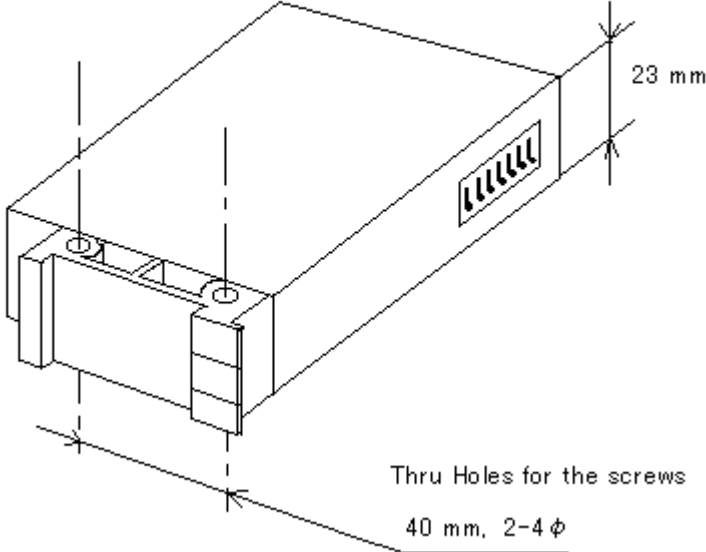

3. Wiring Instruction

3-1. Detection Unit without Control Unit

Both of RS-3500FA and RS-3500FAP are the same wiring feature.

- (1) The Detection Unit has a 3-wire sheath cable, 2 meters long.
When the wire may be extended, do not exceed 30 meters long.
Each wire will be connected as below.

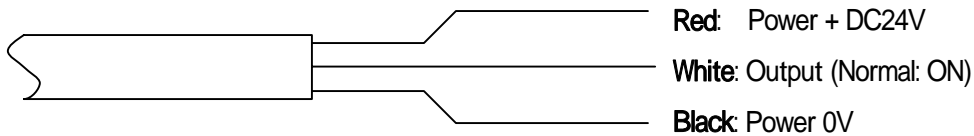

- (2) Connect the red wire (Positive pole) and the black wire (Negative pole) to the power source correctly.
White wire is for an open collector output.

NOTE: Do not miswire with DC power source each other:

NOTE: Use the sensor unit between the power voltages of DC12V to DC24V.

- (3) The output capacity is limited up to 50mA maximum rating. Excessive rating may damage the output circuit.

NOTE: When an inductive load may be applied, the protective treatment for the back electromotive is recommended. The following sample chart shows a hint to add a protective diode (F14C equivalent) to a relay coil load

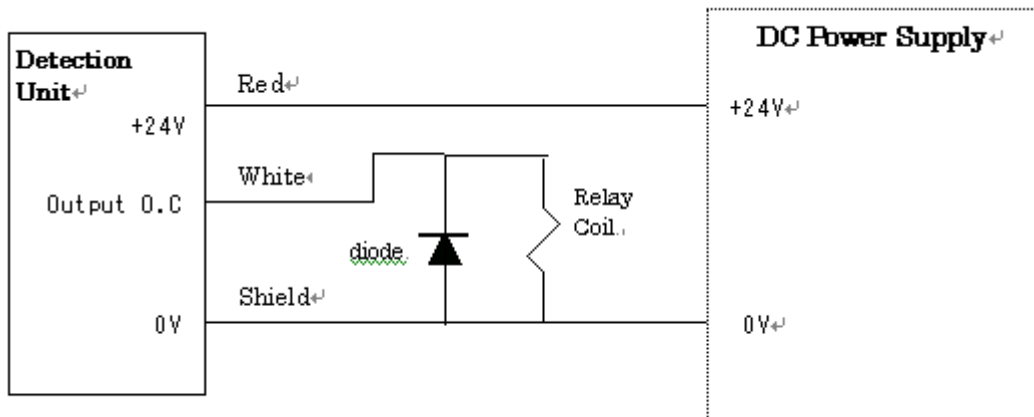

NOTE: To avoid short circuit between each wire after the power is supplied, otherwise undesirable damage may occur:

3-2. Control Unit RS-3500C and Detection Unit RS-3500 series

(Both of RS-3500FA and RS-3500FAP are the same wiring features.)

Use the attached connectors for wiring with the Control Unit RS-3500C. The instruction of the connector is available by a separate sheet.

Refer the wiring information in the below illustration.

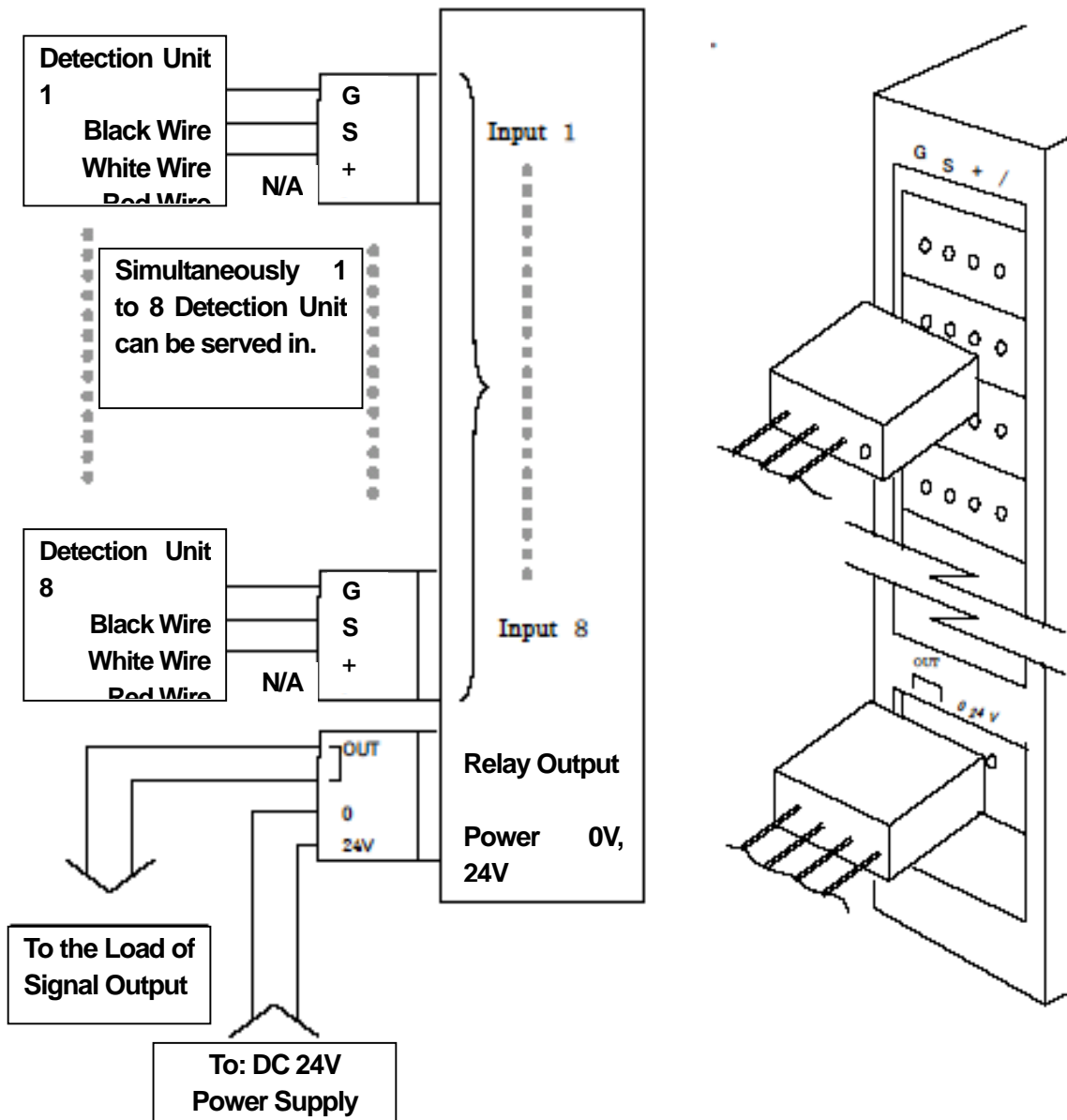

* The output of the Control Unit is one relay contact only.

4. Operation

WARNING: *The following procedure must be implemented after wiring has done and prior to operation.*

4-1. Detection Unit

- (1) After required installation and the wiring have completed, turn on the power. At this moment, Green LED on the Detection Unit will light while the other LED is off. And the output is ON status.
- (2) Then pour a drip of water for the test into the close area of the Detection Unit. Upon the water absorbed into the detection area, the LED of the Detection Unit will change its color into Red. The output of the Detection Unit will become OFF simultaneously.
After then, wipe off the water completely and set the Detection Unit again in the Bracket.

4-2. Control Unit RS-3500C and Detection Unit

- (1) After required installation and the wiring have completed, turn on the power. The LED Display of Power will light on. Then set the Dip Switches on the Control Unit. The detailed function is described the chart in the bottom of this page.

[Adjusting of Dip Switches]

- (2) Put the adequate number of the Dip Switch ON position same as the selected number of the input port of the Control Unit. For example, 5 of the Detection Unit are connected to the input port of 1 through 5, the Dip Switch of 1 through 5 must be turn ON position and other rest of 6 to 8 must be OFF position.
In case that the selected number of the Dip Switch may be OFF in spite the Detection Unit is connected at the same input number, the output signal from the Detection Unit will not be recognized, then both of the Green and Red LED Display on the Control Unit remain unlit.
- (3) Verify the status of all the Detection Unit connected in the Control Unit as described in the above 4.1 section.
- (4) When the Detection Unit shows Red LED on and its output is OFF, the LED Display of the Control Unit shows Red (Alarm) on for the selected number, and Relay contact of the output is OFF=Close.
When all the Detection Unit shows Green LED, the Relay contact of the Control Unit is ON=Open.

Connection and Status Reference Chart

	Input	Detection Unit	Dip Switch	LED Display	Relay Out
1	n	Green ON	n=ON	n = Green ON	OFF = Close
2	n	Red ON 1) Leakage 2) Floating position		n = Red ON	ON = Open
3	n	Not Connected		n = Red ON	ON = Open
4	n	Not Connected	n=OFF	n = unlit	OFF=Close

* "n" represents selected input number from 1 to 8 of the Control Unit.

* If the correspondent number of the Dip Switch may not be set correctly, the Relay output will not function accurately.

4-3. Distinction of the abnormal status

- (1) When the LED of the Detection Unit will not put on, wrong wiring or the damage of the unit by the short circuit of the output that causes the overload may be possible. Stop to use the unit, and check with the wiring and the load status.
- (2) On the Detector, RS-3500FAP, abnormally Green LED may light though the test water penetrates into the detecting area, the Detection Unit may be damaged. Stop using the unit immediately, and consult the vendor or the factory.
- (3) When the incorrect output may be observed though the LED functions correctly, the unit may be damaged by wrong wiring or overloaded output at the output transistor inside. Check the wiring and the load.
- (4) When the Detecting Unit is not placed far into the Bracket as its position, the LED will light Red and output turns OFF. Check the location of the Detecting unit with its Bracket again, and adjust it if placement is wrong.
- (5) When RS3500C Control Unit is applied, be aware that the output of the unit is provided in one pole only in spite the Detection Unit may be served two or more. When one among those connected Detecting Units may turns the output OFF, the singular relay output of the Control Unit becomes ON=Open.
All the Dip Switch must be set correctly as instructed before in this manual.

NOTE: The RS-3500 series sensors utilize the optical devices, and the highly intensive light from outwards (over 1,000 luxes) may disable the function of the Detecting Unit. The normal intensity like the room light may not affects critically, however for safety, you are recommended to avoid any devices which emit the intensive light from the Detection Unit neighborhood, or to shade the light by means of anything applicable.

5. Reset Procedure after Alarm Clearance

WARNING : *The liquid may contain hazardous acids, alkalis, or chemical substances. The following procedure has to be done by a well-trained person who is knowledgeable for that liquid.*

NOTE: *The protection gloves must be worn.*

NOTE: *In case of handling any chemicals that are obliged to wear the protection goggles, masks, etc. by regulation, must follow the regulation.*

- (1) Turn off the power.
- (2) Remove the Detection Unit from the Bracket, and wipe the liquid off.
- (3) Wipe the Bracket and the surroundings. Then reset to follow the process of installation section in this manual.
- (4) Turn on the power again then the reset is completed.
- (5) Check the function of the sensors with the steps of the Section 4.1 to 4.2. Operation
- (6) Achieve periodical maintenance check of the sensor.

NOTE: *The periodical check is recommended at least annually, in accordance with your factory direction.*

WARNING: *This sensor is not explosion proof. Do not use in the area where explosion proof is specified.*

6. Specification

6-1. Detection Unit

Model	RS-3500FA	RS-3500FAP
Supply Voltage	24V DC±10%	
Current	20mA below	
Indication of LED	Leakage: Red, Floating position: Red, Normal: Green	
Output	PNP open collector, 50mA max (normally ON)	
Ambient Temp.	- 10 ~ 60	
Material	Case	PFA
	Cable	FEP, 3-wire sheath
	Lamp	Epoxy (embedded)
Water Protect	Sealed, IP 67 equivalent (IEC)	
Weight	Approx 40g	
Absorbent Paper	Required	Not Required
Bracket	P/N-6430 (PVC)	P/N-6720B (PVC)

6-2. Control Unit

Model	RS-3500C
Input Voltage	24V DC ± 10%
Power Consumption	200mA below
Input	Simultaneously 1 to 8 Input available
LED Display	Independent LED Display for every Input Number(Red, Green x 8) Normal: Green, Leakage: Red No Connection: Unlit both Green and Red
Output	Relay Output, " b " contact × 1 Normally Closed, Leakage or Alarm: Opened, No Power Supplied: Opened
Ambient Temp.	- 10 ~ 60 environment
Case Material	ABS Polymer
Cable connection	Input: 8 Connector ports (Lock feature) Power & Output: 1 Connector port (Lock feature)
Installation	DIN Rail installation, Screw fix up
Wiring Error	Cut circuit detection feature available
Applicable Detection Unit	RS-3500FAP, RS-3500FAP-BZ

* The adopted Connector to the Control Unit is OMRON, XN2A-1430.