

LIQUID LEAK SENSOR

OPERATION MANUAL

(Web Site Downloaded only)

For RS-1000 Series, as following models

Detection Unit (Standalone Type*):

RS-1000DA-24V	RS-1000DAP
RS-1000PA-24V	RS-1000PAP
RS-1000FA-24V	RS-1000FAP

*For **RS-1000 Series Controller Connection Type**, please refer a separate operation manual.

Controller: RS-1000C, RS-1000C-NC, RS-1000CA, RS-1000CA-NC;

Detection Unit: RS-1000D, RS-1000P, RS-1000F, RS-1000PN, RS-1000PP, RS-1000FP

UL Recognized: File No. E176923
CE Mark Compliance: EN61326

TOYOKO KAGAKU CO., LTD.

Components Business Division

370 Ichinotsubo, Nakahara-Ku,

Kawasaki City, Kanagawa Pref.

211-8502, JAPAN

Phone: (044)435-5860 Fax: (044)434-9091

(Patent. 1783360)
MAN-RS1A-05.2012 Revised

Introduction

- We appreciate that you have chosen our Liquid Leak Sensor.
- Before you install or operate it, please read this operation manual thoroughly, and follow the instruction in order to avoid any accidents, malfunction, defects and hazards.
- Please keep this manual with good care as long as the sensor is being operated.

Table of Contents

1. Designation of Sensors	3
(1) RS-1000DA-24V	3
(2) RS-1000PA-24V/ RS-1000FA-24V	3
(3) RS-1000DAP.....	3
(4) RS-1000PAP / RS-1000FAP.....	3
2. Installation	4
2.1. RS-1000DA-24V/ RS-1000PA-24V/ RS-1000FA-24V	4
2.2. RS-1000DAP/ RS-1000PAP/ RS-1000FAP.....	4
3. Wiring Instruction	5
4. Operation and Function Pre-Check	6
5. Resetting after the Leak Detection	7
6. Specification	8
6.1 Detection Unit.....	8
6.2 Bracket	8

1. Designation of Sensors

Standalone Type Detection Unit

(1) RS-1000DA-24V (Body Material: PVC)

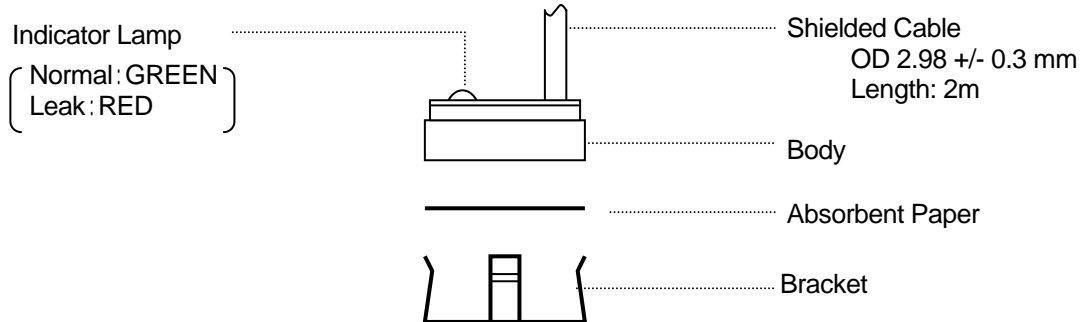

(2) RS-1000PA-24V (Body Material: P.P.)

RS-1000FA-24V (Body Material: PFA)

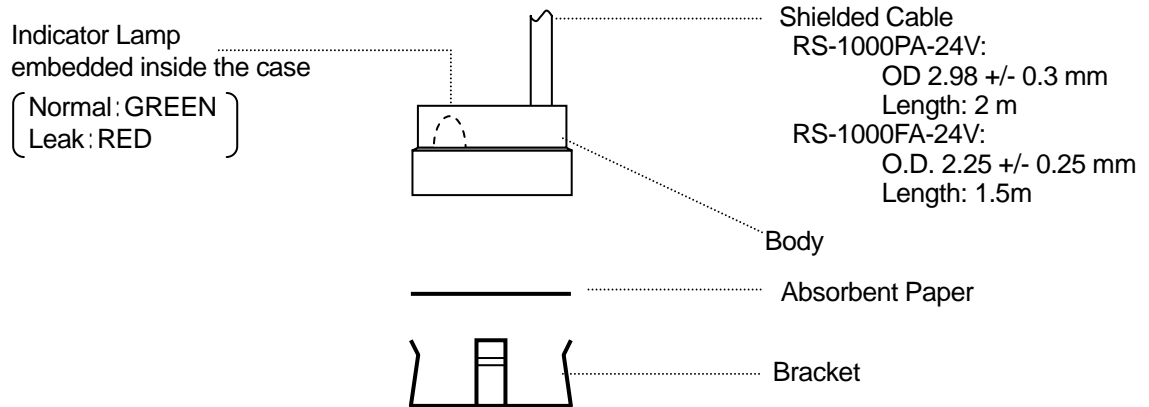

(3) RS-1000DAP (Body Material: PVC)

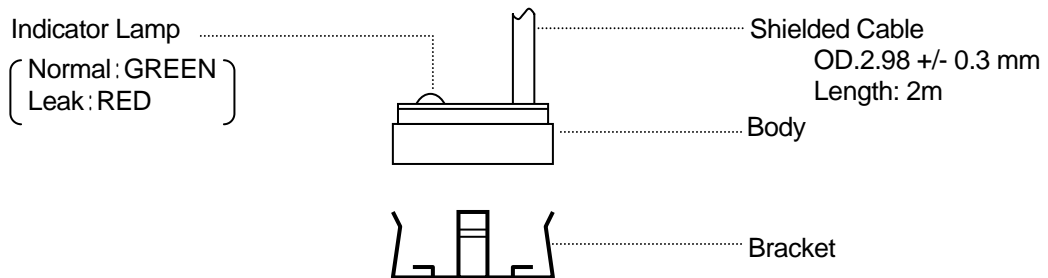

(4) RS-1000PAP (Body Material: P.P.)

RS-1000FAP (Body Material: PFA)

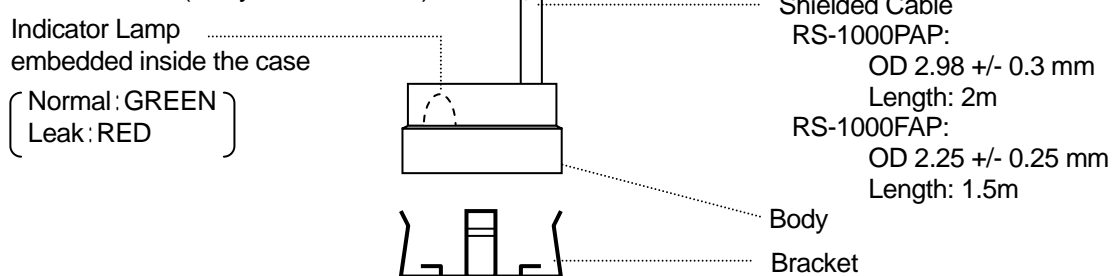

2. Installation

2.1. RS-1000DA-24V/ RS-1000PA-24V/ RS-1000FA-24V

- (1) Place the Bracket of the Detection Unit on the surface where you want to detect the leakage, and fix it firmly.
- (2) Place a piece of the Absorbent Paper onto the Bracket.

NOTE: *Be aware not to use 2 or more pieces of the Paper at a time in the Bracket.*

- (3) To mount the body, push it into the Bracket to the bottom completely.

NOTE: *Verify that the Body has fixed entirely and it does not hook up at intermediate height in the Bracket.*

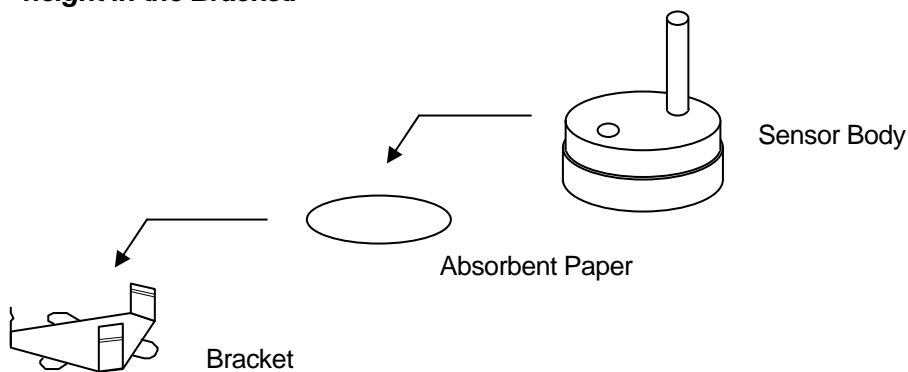

2.2 RS-1000DAP/ RS-1000PAP/ RS-1000FAP (These models are Paperless Type)

- (1) Place the Bracket of the Detection Unit on the surface where you want to detect the leakage, and fix it firmly.
- (2) To mount the Body, push it into the Bracket to the bottom completely.

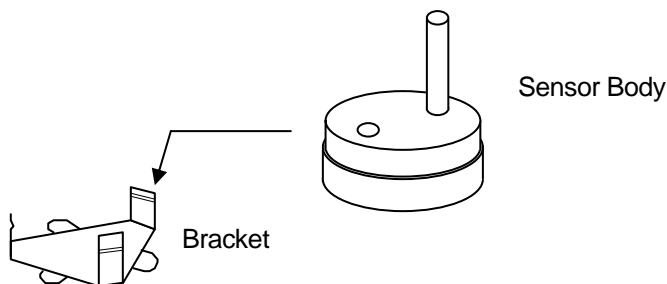

NOTE: *Do not use any Absorbent Paper for these Paperless Type sensors.*

NOTE: *Verify that the Body has fixed entirely and it does not hook up at intermediate height in the Bracket.*

3. Wiring Instruction

(1) The Detection Unit has a 3-core shielded cable, 2 or 1.5 meters long. When the cable needs to be extended, do not exceed a maximum length of 30m for compliance with CE Mark.

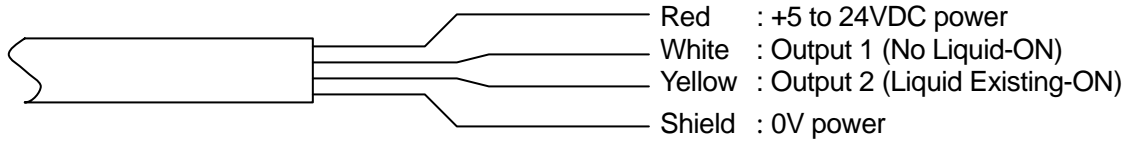

(2) Connect the correct power source to red and shield leads.

CAUTION:

Avoid wrong wiring for DC power. (Red line for PLUS polarity, and Shield line for MINUS.)

(3) Keep the load current not to exceed 50mA. Unless, the output circuit of the sensor may be destroyed.

NOTE: When you apply a relay as a load, add a diode into output connection in parallel configuration in order to limit the back electromotive voltage. Refer to the diagram below.

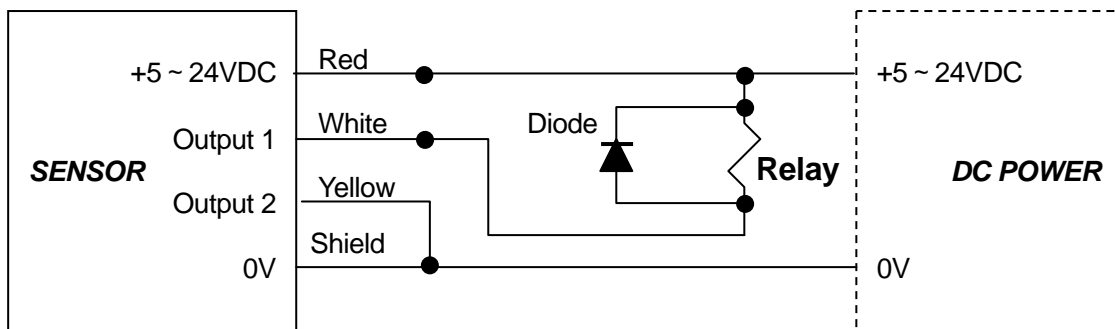

When one of the output lines is not used, it will be recommended to connect with 0V firmly for avoiding unexpected shortage with the red lead by an unconnected free lead end.

NOTE: Don't make any lines be electrically shorted with other lines when the power is applied. Damages may occur on the sensor.

4. Operation and Function Pre-Check

WARNING: *The following procedure must be implemented after wiring has completed and prior to actual operation in the application.*

4.1. RS-1000DA-24V/ RS-1000PA-24V/ RS-1000FA-24V

- (1) Place an Absorbent Paper and Detection Unit into the Bracket properly (Follow the procedure describing in section **2. Installation.**)
- (2) In this condition, the sensor should be on normal condition. Make sure the following appearance and status of the Detection Unit:
 - a. LED on Detection Unit: lit in Green, and
 - b. Signal out through Output 1 (white lead): ON, and/or
 - c. Signal out through Output 2 (yellow lead): OFF
- (3) Remove an Absorbent Paper from the Bracket and place the Body directly on the Bracket.
(Note: This is a wrong installation manner. Allowed for test purpose only.)
- (4) In this condition, the sensor functions even if it detects leakage. Make sure the following appearance and status of the Detection Unit:
 - a. LED on Detection Unit: lit in Red, and
 - b. Signal out: through Output 1 (yellow lead) OFF, and/or
 - c. Signal out through Output 2 (white lead) ON
- (5) Place an Absorbent Paper back in its original place. Now the procedure is completed.

4.2. RS-1000DAP/ RS-1000PAP/ RS-1000FAP

- (1) Place the Detection Unit in to Bracket properly (Follow the procedure describing in section **2. Installation.**)

NOTE: *Do not use any Absorbent Paper.*

- (2) In this condition, the sensor should be on normal condition. Make sure the following appearance and status of the Detection Unit:
 - a. LED on Detection Unit: Green, and
 - b. Signal out: through Output 1 (white lead) ON, and/or
 - c. Signal out through Output 2 (yellow lead) OFF
- (3) Drip the test liquid, such as harmless pure water, at the bottom of the Detection Unit.
- (4) In this condition, the sensor will detect the liquid. Make sure the following appearance and status of the Detection Unit:
 - a. LED on Detection Unit: lit in Red, and
 - b. Signal out through Output 1 (white lead) OFF, and/or
 - c. Signal out: through Output 2 (yellow lead) ON
- (5) Wipe the liquid off around the bottom of the sensor. Then the procedure is completed.

NOTE: *The periodical check is recommended as following your factory protocol or regulations of maintenance plan, but more than at least annually.*

NOTE: *The liquid detecting device in the Detection Unit is photoelectric sensitive device. When the Detection Unit receives a strong light from outside of the sensor Body (larger than 1,000lx), it may cause malfunction of detecting the leak liquid at the sensor from time to time. We recommend you to confirm that no such a strong light emitting instrument may not be located at close position to Detection Unit, or to place a screen avoiding the light may reach to the Detection Unit. The normal room lighting instrument may not effect the Detection Unit.*

5. Resetting after the Leak Detection

WARNING: *The liquid at the use point may contain hazardous acids, alkalis, or chemical substances. The following procedure has to be done by a well-trained person who is knowledgeable for that liquid.*

NOTE: *The protection gloves must be put on.*

NOTE: *In case of handling any chemicals that are obliged to wear the protection goggles, masks, etc. by regulation, you must follow the regulation.*

5.1. RS-1000DA-24V/ RS-1000PA-24V/ RS-1000FA-24V

- (1) Remove Detection Unit from the Bracket and wipe the bottom clearly.
- (2) Remove a wetted Absorbent Paper and wipe the Bracket and its surroundings.
- (3) Install a new Absorbent Paper and place a Detection Unit in to the Bracket properly.
- (4) Follow the section 4.1 (2) through (5) in this manual.

5.2. RS-1000DAP/ RS-1000PAP/ RS-1000FAP

- (1) Remove a Detection Unit from the Bracket and wipe both of the Detection Unit and the Bracket clearly.
- (2) Install a Detection Unit back in to the Bracket properly.

NOTE: *Do not apply any Absorbent Paper.*

- (3) Follow the section 4.2 (2) through (5) in this manual

NOTE: *The periodical check is recommended as following your factory protocol or regulations of maintenance plan, but more than at least annually.*

WARNING: *The Sensor is not designed explosion proof. Do not use in the hazardous area. For this category of UL standard does not allow to use in hazardous area, and UL does not evaluate for explosive circumstances.*

6. Specification

6.1. Detection Unit

Model	RS-1000DA -24V	RS-1000PA -24V	RS-1000FA -24V	RS-1000DAP	RS-1000PAP	RS-1000FAP	
Supply Voltage	5 to 24VDC +/- 5%						
Power Consumption	20mA						
Indication of LED	Red: Leak Green: Normal						
Output	NPN Transistor Open Collector Dual-Output, 50mA						
Ambient Temp.	-10 to 60 deg C (14 to 140 deg F)						
Material	Case	PVC	PP	PFA	PVC	PP	PFA
	Cable**	HT-PVC	HT-PVC	FEP	HT-PVC	HT-PVC	FEP
	Lamp	Epoxy	Epoxy (embedded)		Epoxy	Epoxy (embedded)	
Water Protect	Silicon Stuffed	Sealed		Silicon Stuffed	Sealed		
Weight	45g	55g		45g	55g		
Absorbent Paper	Required			Not Required			
Selectable Bracket	P/N-6417, P/N-6418, P/N-6419			P/N-6416, P/N-6420B			

** Out diameter of the cable is shown as below, but the slight difference may remain as its tolerance because of the manufacturing process.

HT-PVC Cable: O.D. 2.98 +/- 0.3 mm, Length is 2 m (at factory, other than specific request when ordered)

FEP Cable: O.D. 2.25 mm +/- 0.25 mm, Length is 1.5 m (at factory, other than specific request when ordered)

6.2. Bracket

Models	P/N-6417	P/N-6418	P/N-6419	P/N-6416	P/N-6420B
Applicable Sensors	RS-1000DA-24V, RS-1000PA-24V, RS-1000FA-24V			RS-1000DAP, RS-1000PAP, RS-1000FAP	
Material	SUS301 + Ni plated	PVC	PVC	SUS301 + Ni plated	PVC
Remarks	For M3* Screw Holes		For M4* Screw Holes	For M3* Screw Holes	For M4* Screw Holes

*M3, M4 is the nominal code for screw specification designated by Japanese Industrial Standard, JIS B 1101.

Remarks:

For the information of dimensions and outlook shape of these products, these would be found in the brochure of "RS-1000/2000 Series Leak Sensor."